



**NEC's 10 Mbps HIGH CMR
OPEN COLLECTOR OUTPUT TYPE
8-PIN SOP HIGH-SPEED PHOTOCOUPLER**

**PS9814-1
PS9814-2**

FEATURES

- **HIGH ISOLATION VOLTAGE**
BV: 2500 V_{r.m.s.}
- **HIGH COMMON MODE TRANSIENT IMMUNITY**
CMH, CML = ±20 kV/ μs TYP
- **PULSE WIDTH DISTORTION**
| t_{PHL} - t_{PLH} | = 3 ns TYP
- **HIGH-SPEED**
10 Mbps
- **OPEN COLLECTOR OUTPUT**

DESCRIPTION

NEC's PS9814-1 and PS9814-2 is an optically coupled high speed, isolator containing a GaAlAs LED on the input side and a photodiode and a signal processing circuit on the output side on one chip.

This is a plastic S08 type for high density applications.

APPLICATIONS

- MEASUREMENT EQUIPMENT
- PDP
- FACTORY AUTOMATION

ELECTRICAL CHARACTERISTICS (T_A = -40 to +85°C, unless otherwise specified)

PART NUMBER			PS9814-1, PS9814-2			
	SYMBOLS	PARAMETERS	UNITS	MIN	TYP ¹	MAX
Diode	V _F	Forward Voltage, I _F = 10 mA	V	1.4	1.65	1.9
	I _R	Reverse Current, V _R = 3 V	μA			10
	C _t	Terminal Capacitance, V = 0, f = 1 MHz	pF		30	
Detector	I _{OH}	High Level Output Current, V _F = 0.8 mA, V _{CC} = V _O = 5.5 V	μA		0.02	250
	V _{OL}	Low Level Output Voltage ² , V _{CC} = 5.5 V, I _F = 5 mA, I _{OL} = 13 mA	V		0.15	0.6
	I _{CCH}	High Level Supply Current, V _{CC} = 5.5 V, I _F = 0 mA, V _O = open (PS9814-1)	mA		3	8
	I _{CCH}	High Level Supply Current, V _{CC} = 5.5 V, I _F = 0 mA, V _O = open (PS9814-2)	mA			15
	I _{CCL}	Low Level Supply Current, V _{CC} = 5.5 V, I _F = 10 mA, V _O = open (PS9814-1)	mA		7.0	11
	I _{CCL}	Low Level Supply Current, V _{CC} = 5.5 V, I _F = 10 mA, V _O = open (PS9814-2)	mA			21

(Continued on next page)

ELECTRICAL CHARACTERISTICS ($T_A = -40$ to $+85^\circ\text{C}$, unless otherwise specified)

PART NUMBER		PS9814-1, PS9814-2			
SYMBOLS	PARAMETERS	UNITS	MIN	TYP ¹	MAX
IFHL	Threshold Input Current (H→L), $V_{CC} = 5\text{ V}$, $V_O = 0.8\text{ V}$, $R_L = 350\ \Omega$	mA		2	5
RI-O	Isolation Resistance, $V_{I-O} = 1\text{ kVdc}$, $R_H = 40$ to 60% , $T_A = 25^\circ\text{C}$	Ω	10^{11}		
CI-O	Isolation Capacitance, $V = 0$, $f = 1\text{ MHz}$	pF		0.6	
tPHL	Propagation Delay Time (H→L) ³ , $V_{CC} = 5\text{ V}$, $R_L = 350\ \Omega$, $I_F = 7.5\text{ mA}$	ns		54	75
					100
tPLH	Propagation Delay Time (L→H) ³ , $V_{CC} = 5\text{ V}$, $R_L = 350\ \Omega$, $I_F = 7.5\text{ mA}$	ns		51	75
					100
tr	Rise Time, $V_{CC} = 5\text{ V}$, $R_L = 350\ \Omega$, $I_F = 7.5\text{ mA}$	ns		20	
tf	Fall Time, $V_{CC} = 5\text{ V}$, $R_L = 350\ \Omega$, $I_F = 7.5\text{ mA}$	ns		10	
tPHL-tPLH	Pulse Width Distortion, $V_{CC} = 5\text{ V}$, $R_L = 350\ \Omega$, $I_F = 7.5\text{ mA}$			3	50
tPSK	Propagation Delay Skew, $V_{CC} = 5\text{ V}$, $R_L = 350\ \Omega$, $I_F = 7.5\text{ mA}$				60
CMH	Common Mode Transient Immunity at High Level Output ⁴ , $R_L = 350\ \Omega$, $T_A = 25^\circ\text{C}$, $I_F = 0\text{ mA}$, $V_O(\text{MIN}) = 2\text{ V}$, $k\Omega$, $V_{CM} = 1\text{ kV}$	kV/ μs	10	20	
CML	Common Mode Transient Immunity at Low Level Output ⁴ , $R_L = 350\ \Omega$, $T_A = 25^\circ\text{C}$, $I_F = 7.5\text{ mA}$, $V_O(\text{MIN}) = 0.8\text{ V}$, $k\Omega$, $V_{CM} = 1\text{ kV}$		10	20	

Notes:

1. Typical values at $T_A = 25^\circ\text{C}$
2. VOL of 2 V or more may be output if LED has a signal applied while $V_{CC} = 2.6\text{ V}$ or less. It is important to confirm the characteristics during power up and power down, before using this device.
3. Test circuit for propagation delay time

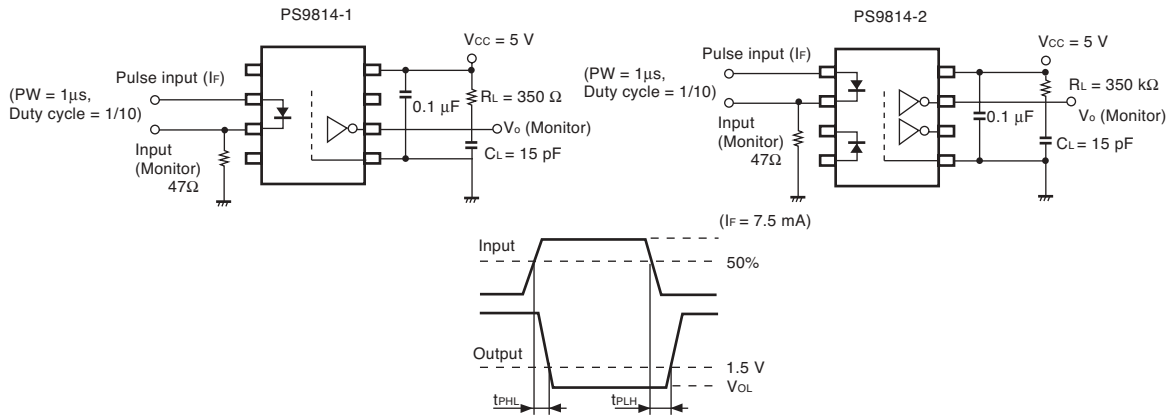

4. Test circuit for common mode transient immunity.

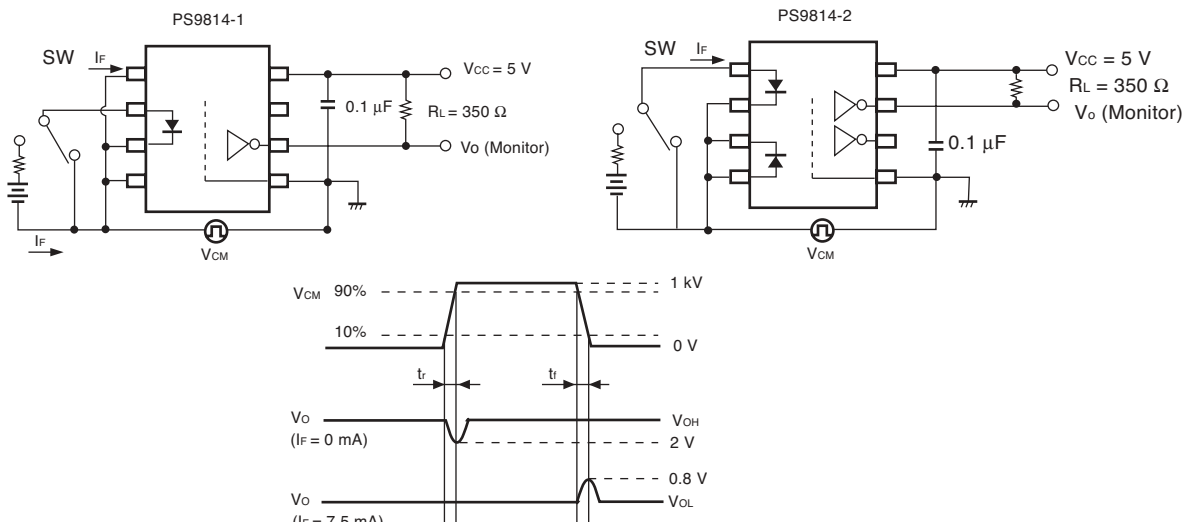

Remark CL includes probe and stray wiring capacitance

PS9814-1, PS9814-2

ABSOLUTE MAXIMUM RATINGS¹

(T_A = 25°C, unless otherwise specified)

SYMBOLS	PARAMETERS	UNITS	RATINGS PS9814-1,-2
Diode			
I _F	Forward Current (DC) ²	mA	30
V _R	Reverse Voltage	V	5
Detector			
V _{CC}	Supply Voltage	V	7
V _O	Output Voltage	V	7
I _O	Output Current	mA	25
P _C	Power Dissipation ³	mW	40
Coupled			
BV	Isolation Voltage ⁴	V _{r.m.s.}	2500
T _{STG}	Storage Temperature	°C	-55 to +125
T _A	Operating Ambient Temperature	°C	-40 to +85

Notes:

- Operation in excess of any one of these parameters may result in permanent damage.
- Reduced to 0.3 mw/°C at T_A = 25 °C or more.
- Applies to output pin V_O. Reduced to 1.5 mw/°C at T_A = 65°C or more.
- AC voltage for 1 minute at T_A = 25 °C, RH = 60 % between input and output.

RECOMMENDED OPERATING CONDITIONS

(T_A = 25°C, unless otherwise specified)

SYMBOLS	PARAMETERS	UNITS	MIN	TYP	MAX
V _{FL}	Forward Current (DC) ²	mA	0		0.8
I _{FH}	Reverse Voltage	V	6.3	10	12.5
V _{CC}	Operating Ambient Temperature	°C	4.5	5.0	5.5
N	TTL (R _L = 1 k Ω, loads)				5

OUTLINE DIMENSIONS (Units in mm)

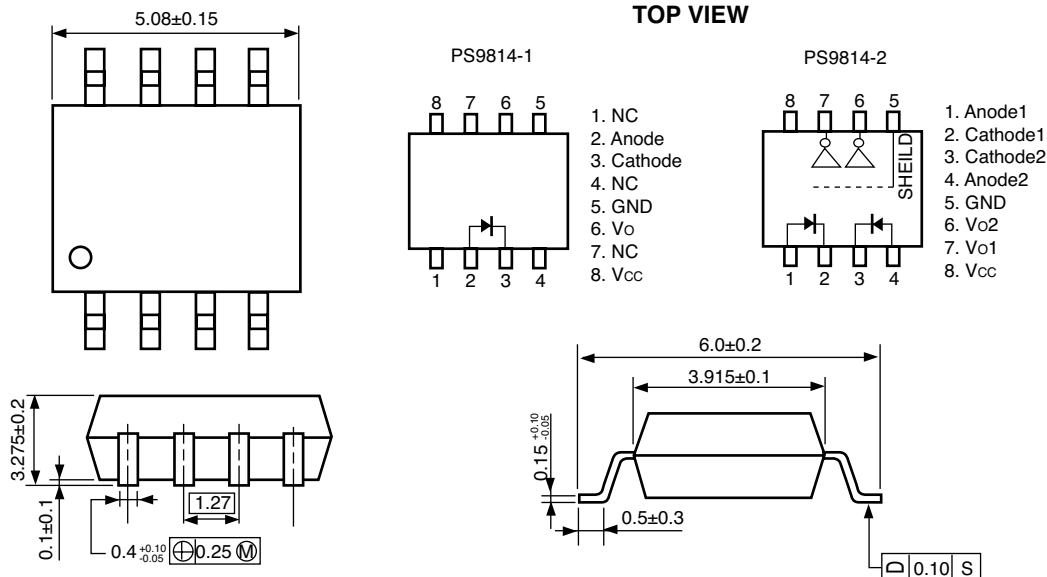

Life Support Applications

These NEC products are not intended for use in life support devices, appliances, or systems where the malfunction of these products can reasonably be expected to result in personal injury. The customers of CEL using or selling these products for use in such applications do so at their own risk and agree to fully indemnify CEL for all damages resulting from such improper use or sale.

CEL California Eastern Laboratories, Your source for NEC RF, Microwave, Optoelectronic, and Fiber Optic Semiconductor Devices.

4590 Patrick Henry Drive • Santa Clara, CA 95054-1817 • (408) 988-3500 • FAX (408) 988-0279 • www.cel.com

DATA SUBJECT TO CHANGE WITHOUT NOTICE

10/13/2003